

HomePNA to Ethernet Adapter

User's Guide

INTRODUCTION

This HomePNA to Ethernet Adapter connects any Ethernet device to a high speed access device or to a HomeNet LAN for Internet and Intranet access. This Adapter brings you the newest Ethernet compatible technology that uses the telephone wiring as the network's physical wiring thereby eliminating the need to install new wiring. It is designed to operate on the telephone wire installed in homes.

With this Adapter, every RJ-11 jack is Internet-Ready. Devices connected to this Adapter can share any high speed Internet access line-V.90, ISDN, cable, xDSL or wire-less modem.

This Adapter allows you to connect PCs and Ethernet enabled devices, such as Switch, HUB and printers, to a HomeNet LAN by simply plugging into the existing RJ-11 jacks. This Adapter's 1 Mbps throughput provides the bandwidth necessary to support existing networking applications such as application sharing, peripheral sharing and file sharing.

For providing a LAN networking solution, the Adapter acts as a high speed network access device for 1 Mbps Internet service that shares the existing telephone wire with POTS (Plain Old Telephone Service) service. This allows multiple PCs to access the Internet concurrently. The Adapter also distributes bandwidth within a customer premises that use V.90, ISDN, Cable, wire-less and xDSL modems to deliver high-speed access to the outside of the customer premises.

Features

- Plug & Play
- Protocol independent
- Using existing phone jacks to build a network
- Shares high speed Internet access
- Every RJ-11 Phone Jack is Internet ready
- 1 port 1Mbps connection compliant with HomePNA 1.1 standard
- Adjustable transmitting power level to use in various wiring environment
- Adjustable receiving sensitivity to combat crosstalk
- Standard 10BaseT Ethernet port for connecting to Ethernet or cable modem

Specifications

- Network specification
- IEEE 802.3 10BaseT Ethernet in half duplex mode

HARDWARE INSTALLATION

Parts Names and Functions

LED Indicators on the Front Panel

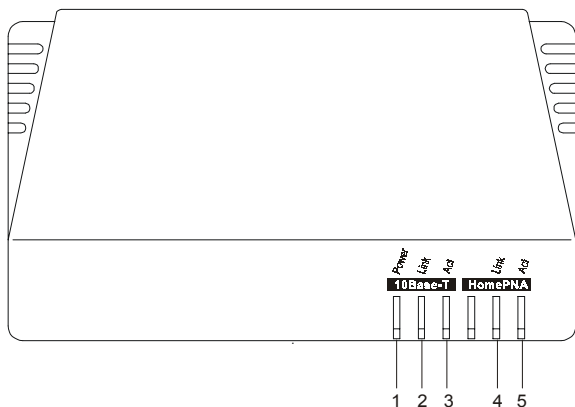

	LED	Status		
		Glowing	Dimming	Flashing
①	Power	DC 5V power feeding in	Not powered	N/A
②	Link	10 Base-T Link	Disconnected or Link failed	N/A
③	Act	Receiving or Transmitting	No data flow	Slow data rate
④	Link	HomePNA Link	Disconnected or Link failed	N/A
⑤	Act	Receiving or Transmitting	No data flow	Linked only (no data flow).

Ports on the Rear Panel

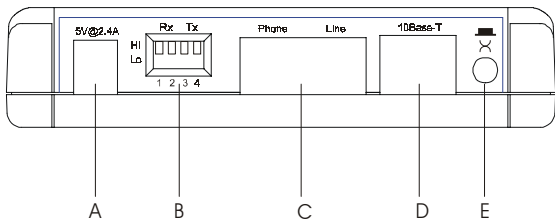

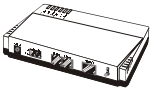

	Port Name	Type	Functions
A	5V DC	DC	Connects to the power adapter plug.
B	HomeNet Setting	Piano switch	Adjusting the Transmitting power level and Receiving sensitivity to combat crosstalk.
C	HomeNet	RJ-11	Connects to HomePNA devices
D	Ethernet	RJ-45	Connects to Ethernet port on Cable, xDSL Modem or Switch for Internet Access.
E	UPLINK	Push button	Changes the Ethernet connection to crossover or parallel.

Essential Hardwares

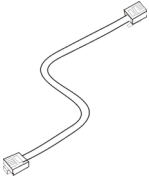
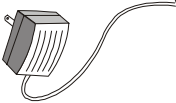
Items Included	Description	Purpose
	HomePNA to Ethernet Adapter	Main Unit

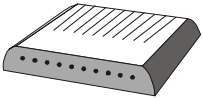
	<p>Telephone wire</p>	<p>Connects from HomeNet Port of the main unit to phone jack on the wall outlet.</p>
	<p>DC 5V Power adapter</p>	<p>Connects from Power Port of the main unit into a wall outlet</p>

<p>Additional Required Items (Not included)</p>	<p>Description</p>
	<p>A well-installed WAN environment (Cable Modem or xDSL Modem)</p>
	<p>A well-installed LAN environment</p>

HomeNET Setting

The **Piano Switch** (refer to the previous section “**Parts Names and Functions**”) on the rear panel of the HomePNA to Ethernet Adapter is used to adjust the receiving sensitivity and the transmitting power levels. There are four levels for both settings, however, the definitions for the levels of two settings are the opposite to each other as described below.

Receiving sensitivity (receiving signal threshold level): when the signal amplitude is lower than the receiving signal level, it means this signal is been rejected. Increasing the sensitivity level will intensify the receiving sensitivity. A higher sensitivity level indicates a lower receiving signal threshold level.

	Pin 1	Pin 2	Adjustable Receiving Sensitivity
	High	High	Level 1
	High	Low	Level 2
	Low	High	Level 3 (Default value)
	Low	Low	Level 4

Transmitting power level: Rising the transmitting power level will intensify the transmitting signal power .A higher level being set will require to

increase the transmitting cable length , however, it results in more crosstalk.

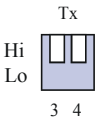
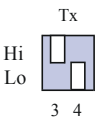
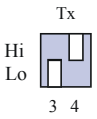
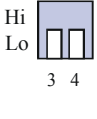
	Pin3	Pin4	Adjustable Transmitting power level
	High	High	Level 4
	High	Low	Level 3
	Low	High	Level 2 (Default Value)
	Low	Low	Level 1

The Default Settings

The default settings as shown below is recommended to remain, for inappropriate setting may cause the device malfunctioning. Consult your dealer for changing the default values.

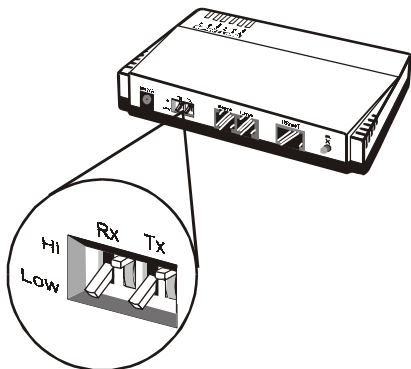

Hardware Connections

1. Select a convenient location for the Adapter near the PC or Ethernet device to which it will be connected. The Adapter should be kept away from excessive heat.
2. Using one telephone wire to connect one of the HomeNet ports and the other end to an RJ-11 jack on the wall. Using another telephone wire to connect the other HomeNet port to a telephone set.
3. Connect one end of the 10BASE-T cable to the 10Base-T port and the other end to your Ethernet-equipped device. The **uplink push button** is used to uplink this adapter to an Ethernet device. Check the type of the Ethernet cable (parallel or crossover) you are using to decide to push the button or not.
4. Connect the Power Adapter to the 5V DC port into a wall outlet.

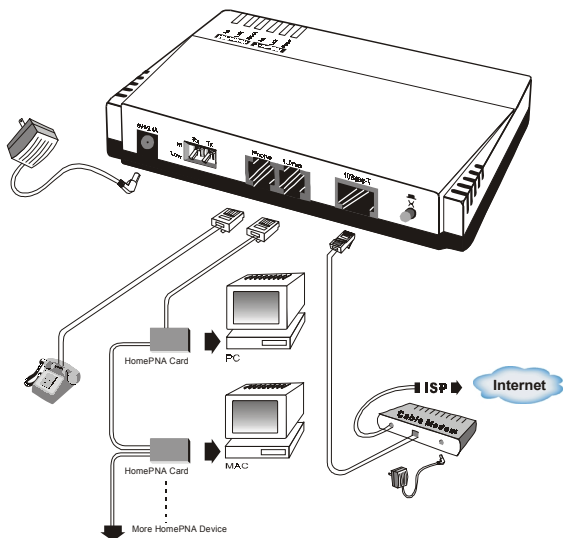

The Adapter can be used to connect any device with an Ethernet 10BASE-T port to a Home phonline network. The figure above shows how to connect a cable modem to a Home phonline network using a HomePNA device. Follow the same steps to connect any device with an Ethernet 10BASE-T interface such as a HUB or printer, to a Home phonline network.

Now you should have connected the Ethernet port, HomeNet port and the Power port to the appropriate devices or lines. You will observe the following LED behavior after the Adapter is powered up and connected to the network.

- POWER ON
- Ethernet Link/Act ON

HomeNet Link/Act ON

For more information on the operations of LEDs
see section **"LED INDICATORS ON THE
FRONT PANEL"**

TROUBLESHOOTING

The Adapter has been designed to be a reliable and easy to use connection device. Please refer to the list below to aid in troubleshooting.

The Power (green) LED is off.

- *Make sure the power adapter is properly plugged into a live electrical outlet.*

The Ethernet or HomeNet Link/Act LED (green) is off.

- *Make sure the connection to these two ports is secure.*
- *The Ethernet or HomePNA device to which you are connected should be powered on and properly configured.*

SPECIFICATIONS

Standards

- IEEE802.3 10BASE-T Ethernet compliant
- HomePNA 1.1 specifications compliant

Data Rates

- Home Networking: 1 Mbps
- Ethernet: 10 Mbps

Distances

- Home Networking: 150 meter maximum between the two farthest nodes on the LAN
- Ethernet: 100 meter maximum between two farthest nodes on the LAN

Power consumption: 5V DC IN, Less than 2W.

Certifications:

- VCCI Class II
- JATE

LEDs

- Power
- HomeNet Link/Activity
- Ethernet Link/Activity

Connectors

- One RJ-11 for connecting with HomePNA device
- One RJ-45 for connecting with a 10BASE-T network

Cables

- Home Networking: standard home telephone wire
- Ethernet: CAT 3, CAT5 or better UTP